

S:\Current Models\1Standard Models\EL-10xxADC-A and EL-10xxGDC-A (-MS)\EL-10xxADC-A and EL-10xxGDC-A (-MS).dwg, 12/29/2015 1:43:51 PM, PDFCreator

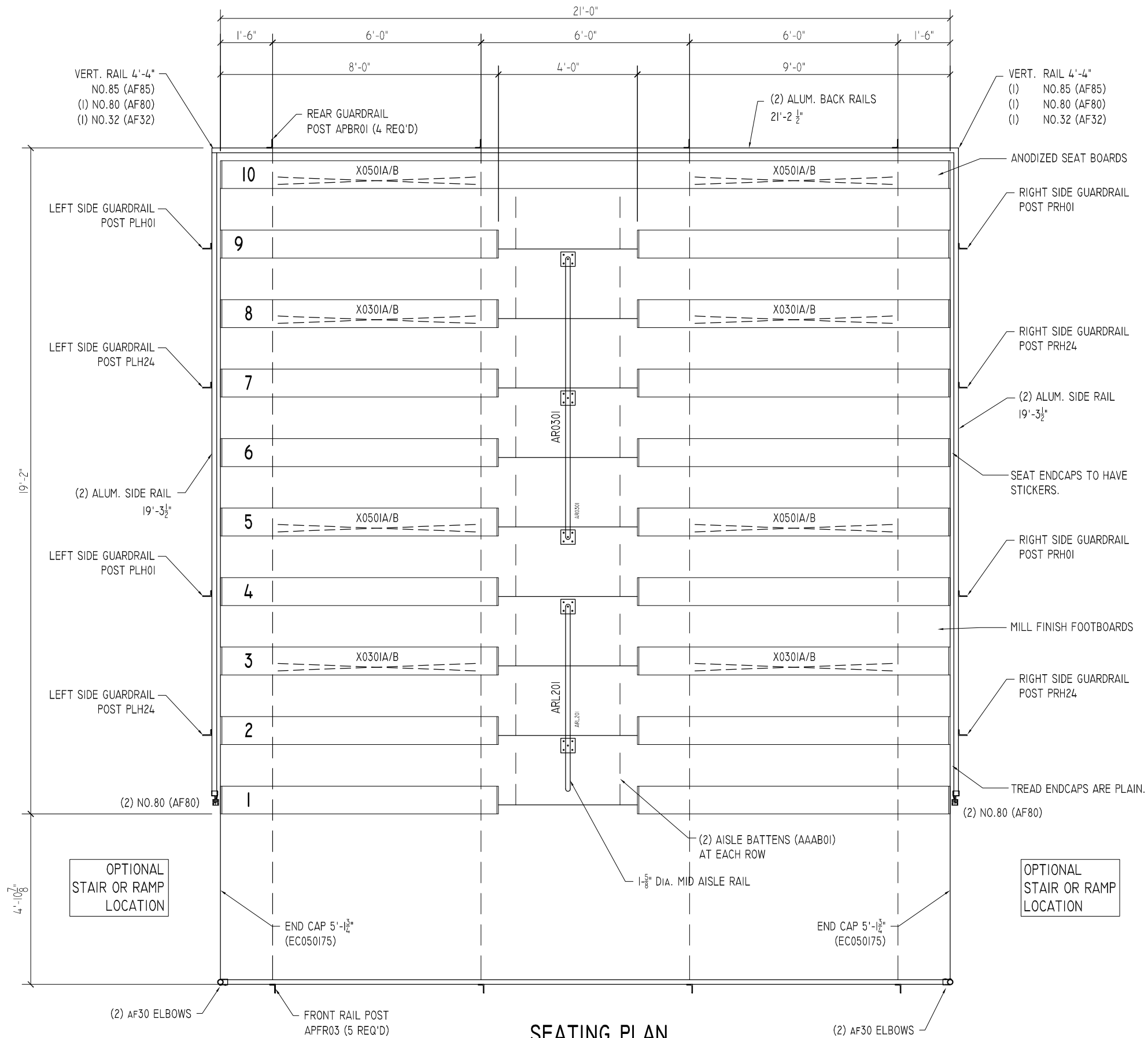

SEATING PLAN

SCALE: NONE

NET SEATS = 113

2810 Sydney Road
Plant City, Florida 33566
Phone: 813-305-1415
Fax: 813-305-1419
www.gtgrandstands.com

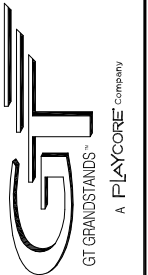

SEATING PLAN
ELEVATED 10 ROW BLEACHER
WITH AISLE

EL-1021ADC-A AND EL-1021GDC-A
OPTIONAL -MS (MUD SILLS)

DRAWN BY
CHECKED BY
DATE MAY 2010
SCALE NOTED
JOB NO. EL-1021ADC-A EL-1021GDC-A
DWG NO.

S:\Current Models\1Standard Models\EL-10xxADC-A and EL-10xxGDC-A (-MS)\EL-10xxADC-A and EL-10xxGDC-A (-MS).dwg, 12/29/2015 1:43:55 PM, PDFCreator

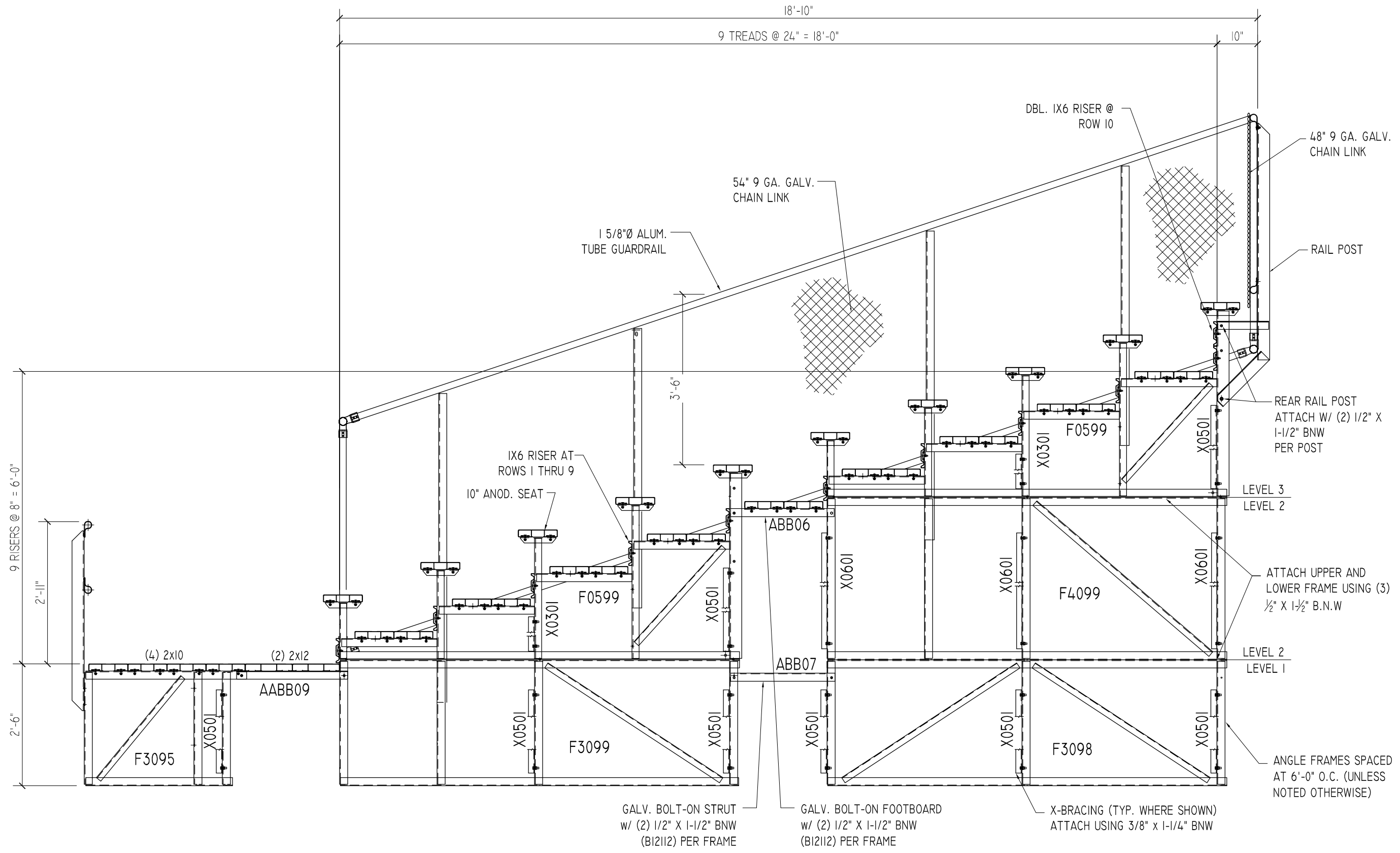

TYPICAL SECTION THRU BLEACHER

SCALE: 1/2" = 1'-0"

**SECTION THRU
ELEVATED 10 ROW BLEACHER
WITH AISLE**

**EL-10xxADC-A AND EL-10xxGDC-A
OPTIONAL -MS (MUD SILLS)**

DRAWN BY
CHECKED BY
DATE MAY 2010
SCALE NOTED
JOB NO. EL-10xxADC-A EL-10xxGDC-A
DWG NO.

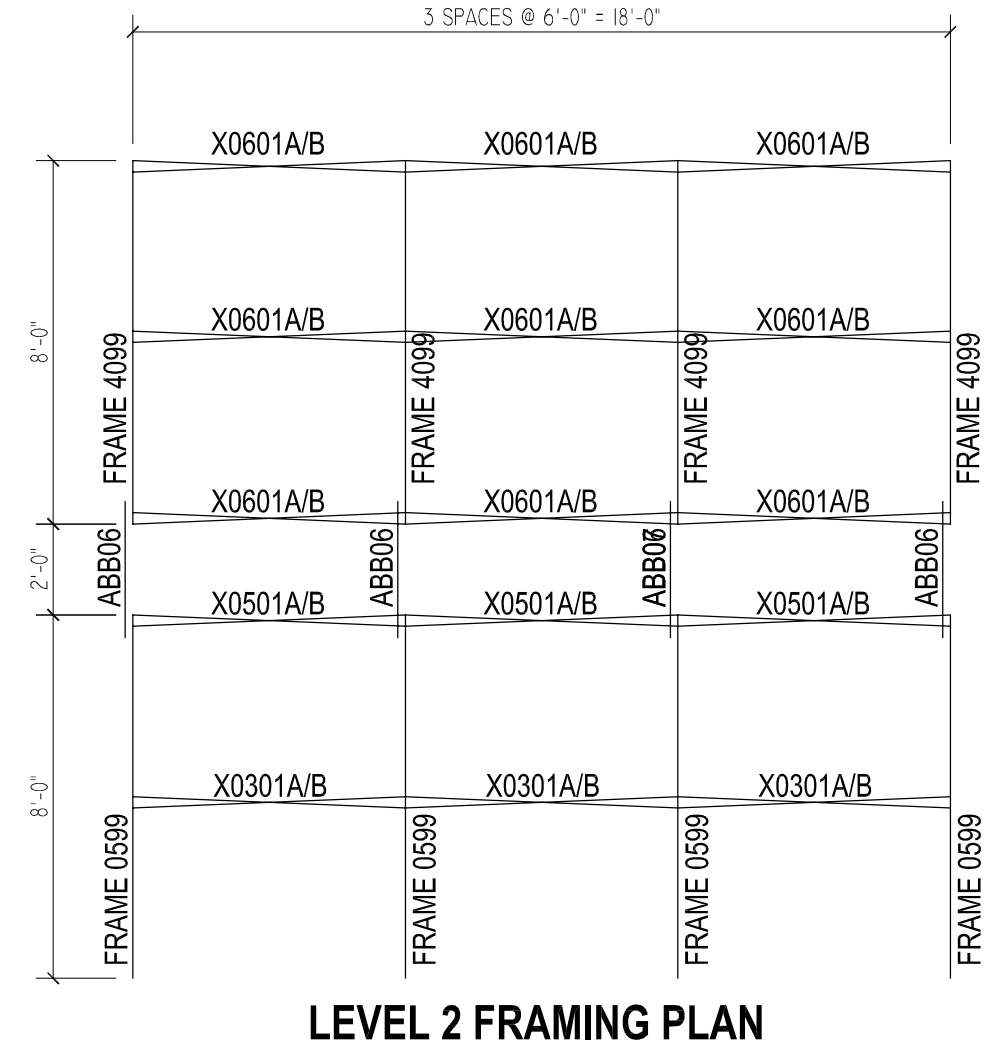
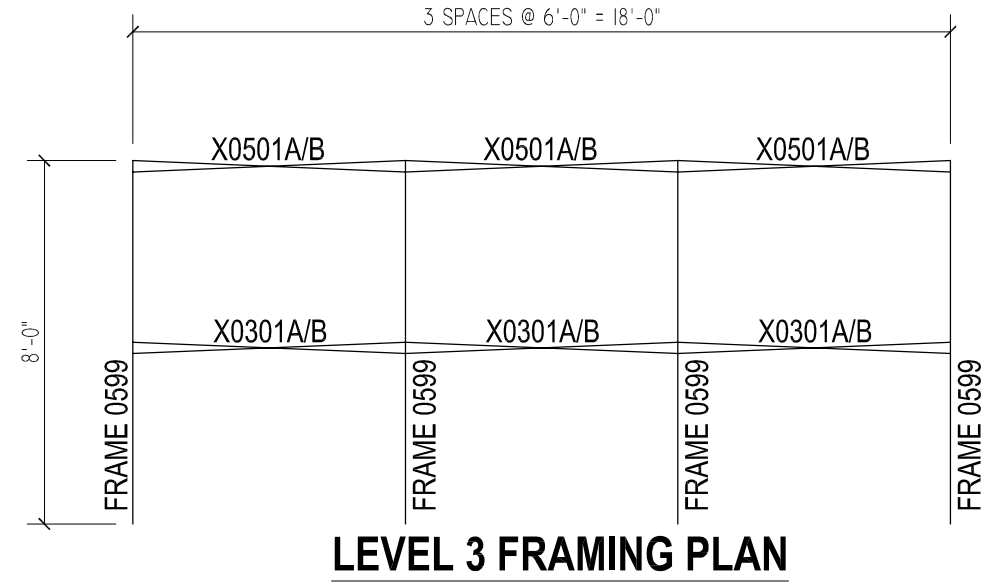
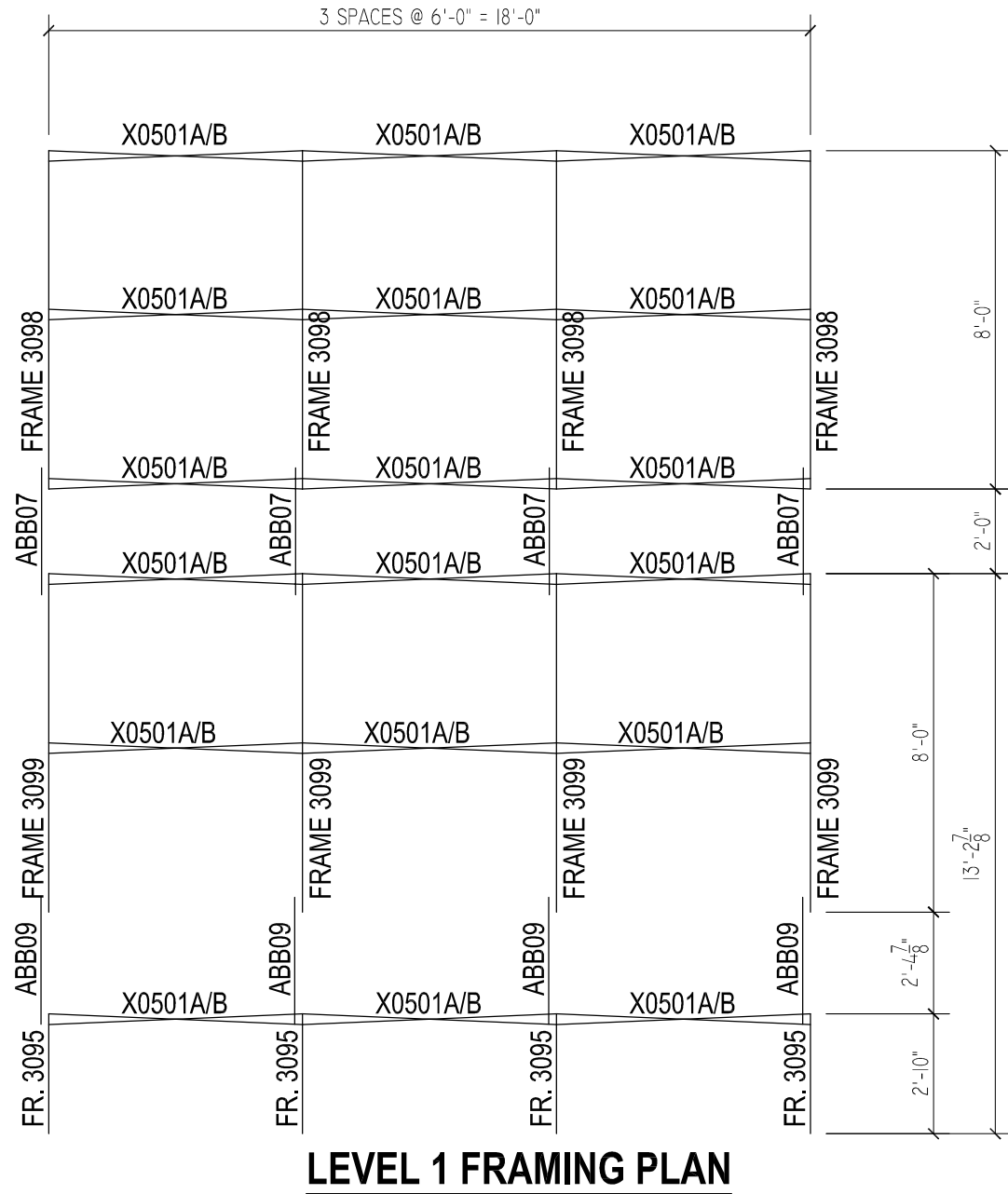

S:\Current Models\1Standard Models\EL-10xxADC-A and EL-10xxGDC-A (-MS)\EL-10xxADC-A and EL-10xxGDC-A (-MS).dwg, 12/29/2015 1:44:05 PM, PDFCreator

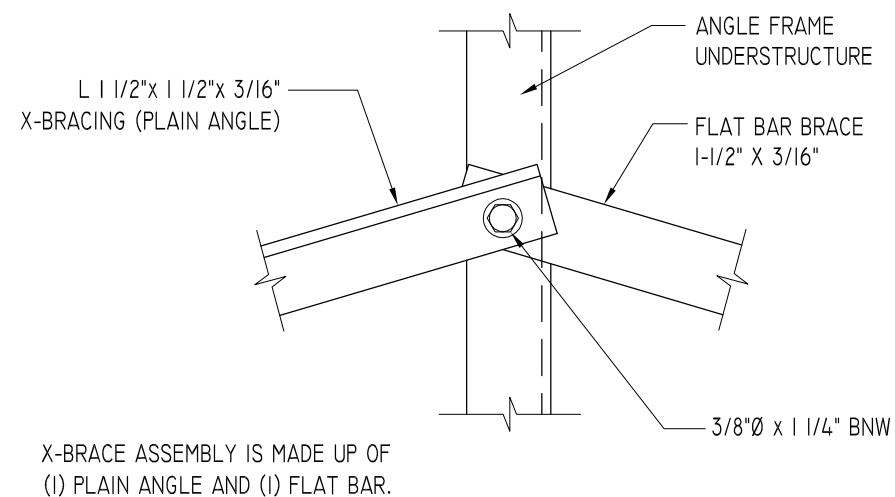

TYPICAL X-BRACE TO FRAME CONN.

SCALE: 3" = 1'-0"

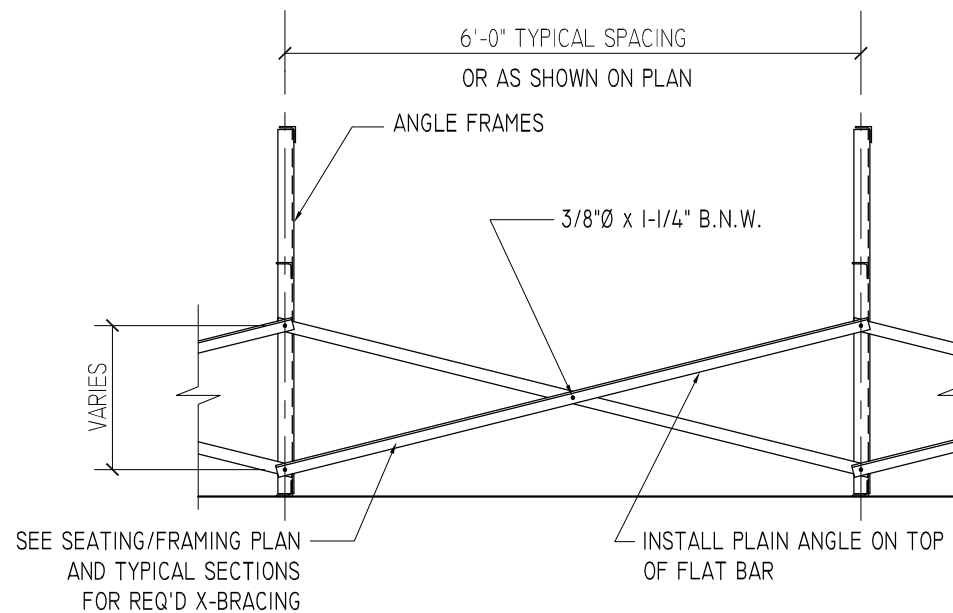

TYPICAL BRACING LAYOUT

SCALE: 1/2" = 1'-0"

PRE-ASSEMBLE X-BRACE SETS. EACH SET CONSISTS OF A 'PART A (PLAIN ANGLE)' AND A 'PART B (FLAT BAR)'. PLACE THE PIECES TOGETHER AT THE FLAT SIDES AND CONNECT USING A 3/8" x 1-1/4" B.N.W.

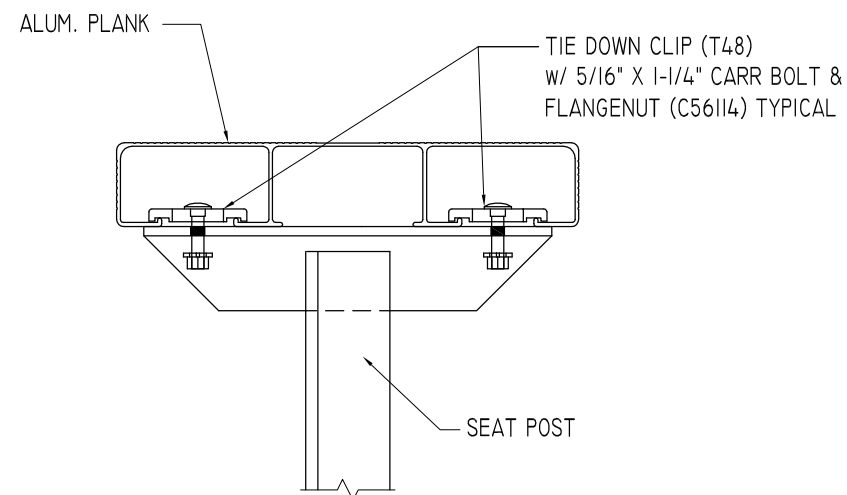
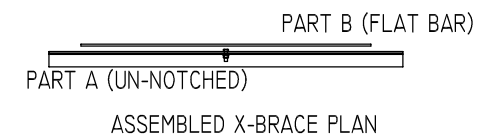

SEAT PLANK INSTALLATION

SCALE: 3" = 1'-0"

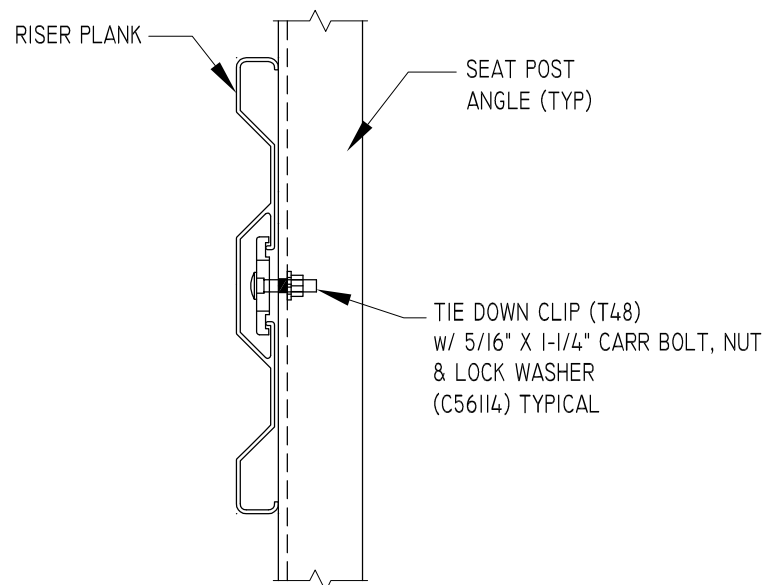

TYPICAL RISER INSTALLATION

SCALE: 3" = 1'-0"

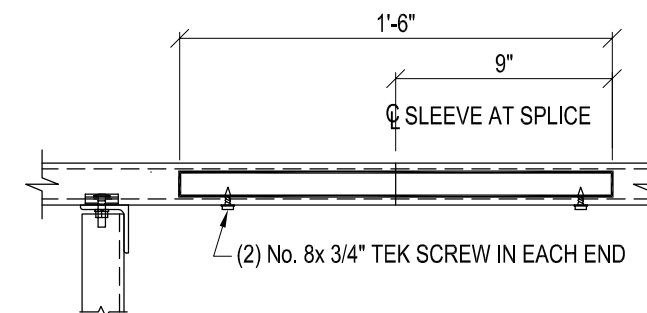

ALUMINUM SLEEVE DETAIL

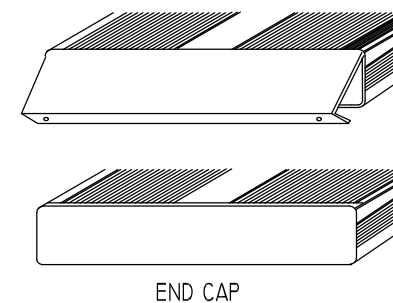

END CAP

1. LOCATE THE CHANNEL END CAP AS SHOWN, WITH THE WIDER FLANGE ON BOTTOM.
2. TAP THE CHANNEL INTO PLACE WITH A RUBBER MALLET OR SOFT WOOD.
3. DRILL (2) No.8 x 3/4" TEK SCREWS THRU END CAP AND BOTTOM FLANGE OF PLANK
4. ENDCAPS WITH STICKERS ARE TO GO AT ENDS OF SEAT PLANKS, PLAIN ENDCAPS GO ON ALL OTHER BOARDS.

ENDCAP INSTALLATION DETAIL

SCALE: 3" = 1'-0"

EL-10xxADC-A AND EL-10xxGDC-A
OPTIONAL -MS (MUD SILLS)

MISC. DETAILS
ELEVATED 10 ROW BLEACHER
WITH AISLE

2810 Sydney Road
Plant City, Florida 33566
Phone: 813-305-1415
Fax: 813-305-1419
WWW.GTGRANDSTANDS.COM

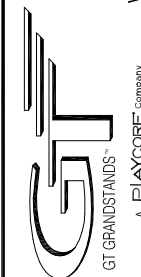

DRAWN BY
CHECKED BY
DATE
MAY 2010
SCALE
NOTED
JOB NO.
EL-10xxADC-A
EL-10xxGDC-A
DWG NO.

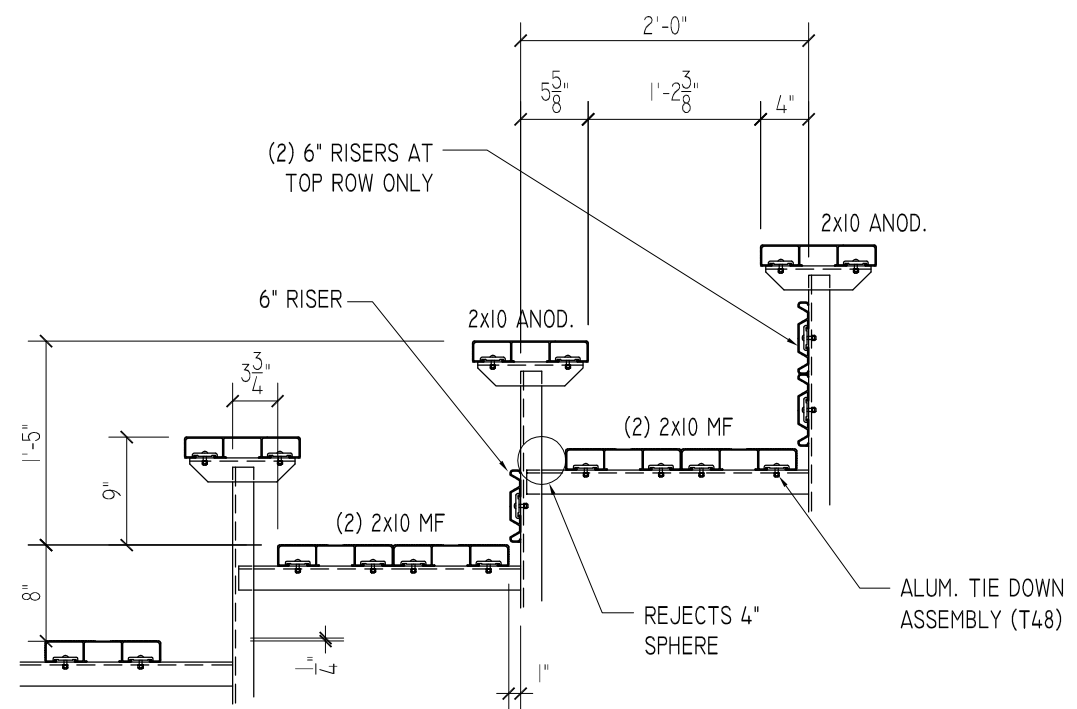

CONDITION AT SEATS
SCALE: 3/4" = 1'-0"

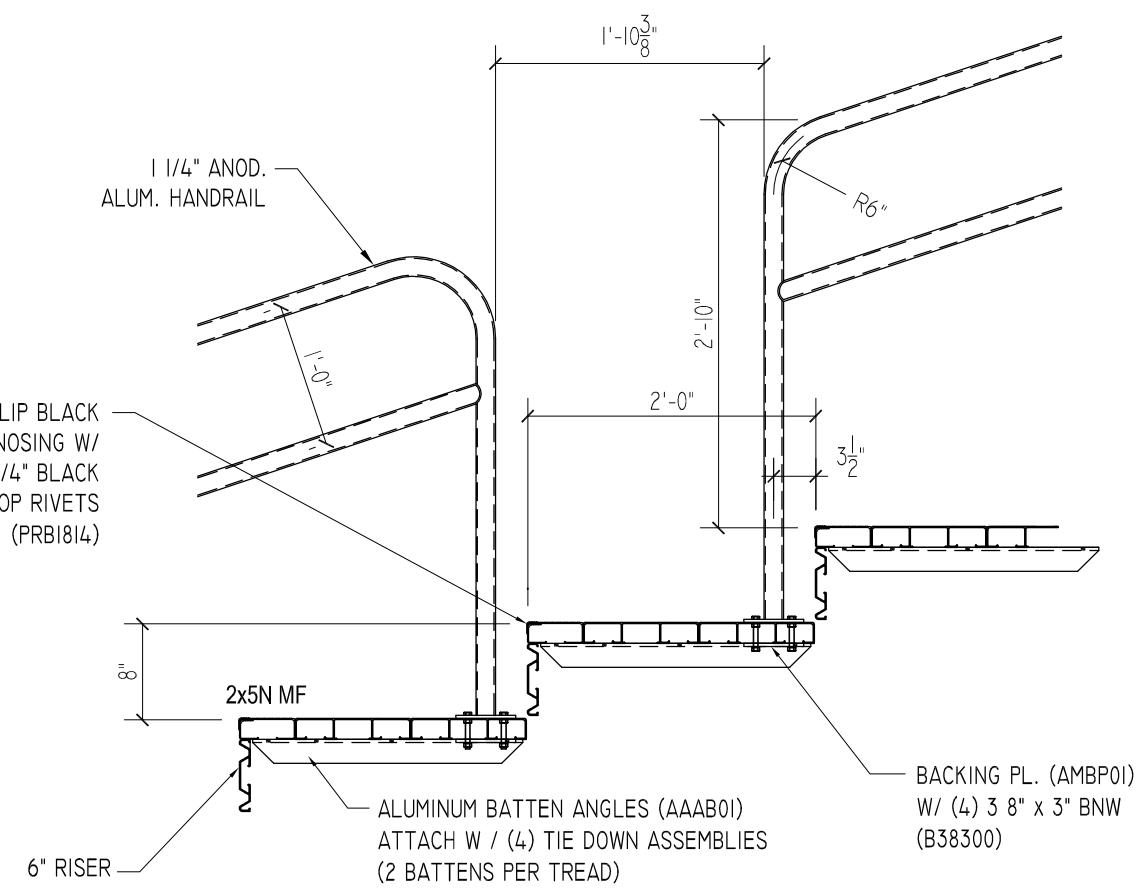

CONDITION AT AISLE
SCALE: 3/4" = 1'-0"

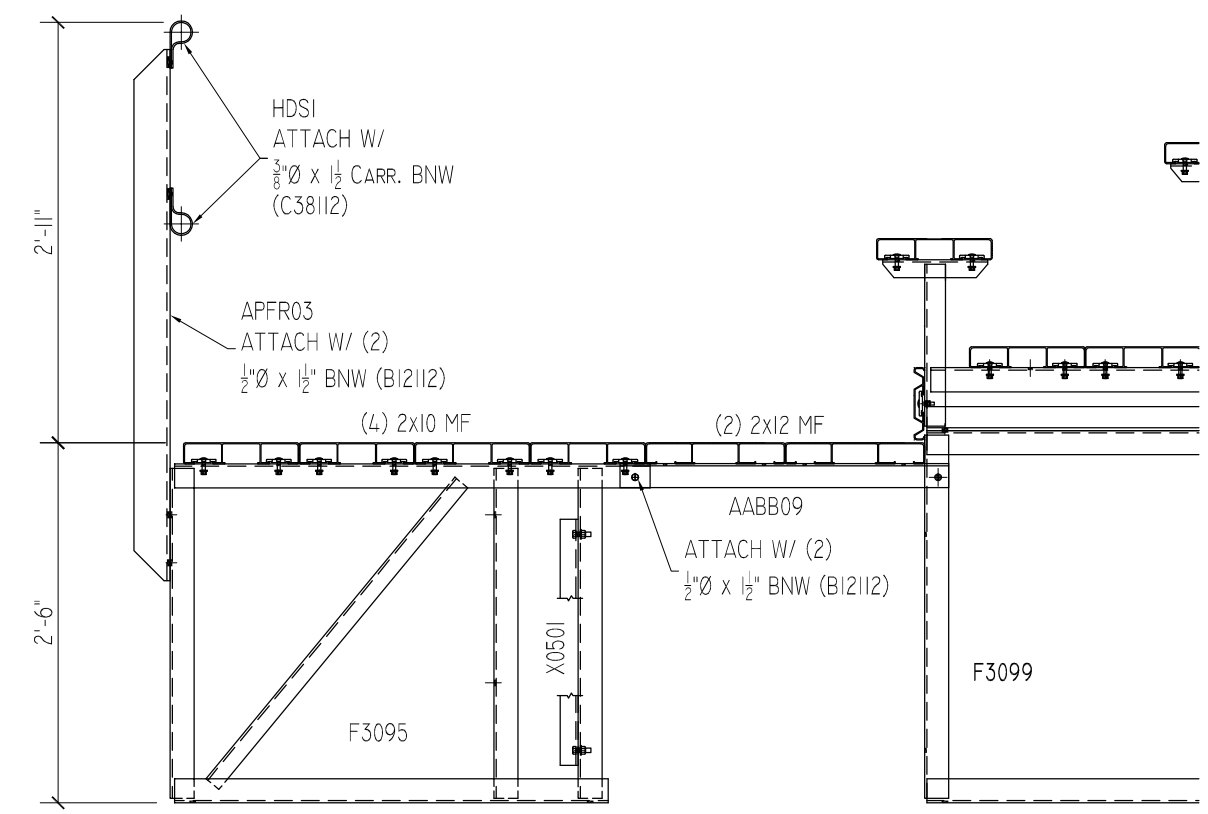

CONDITION AT FRONT WALK
SCALE: 3/4" = 1'-0"

S:\Current Models\1Standard Models\EL-10xxADC-A and EL-10xxGDC-A (-MS)\EL-10xxADC-A and EL-10xxGDC-A (-MS).dwg, 12/29/2015 1:44:16 PM, PDFCreator

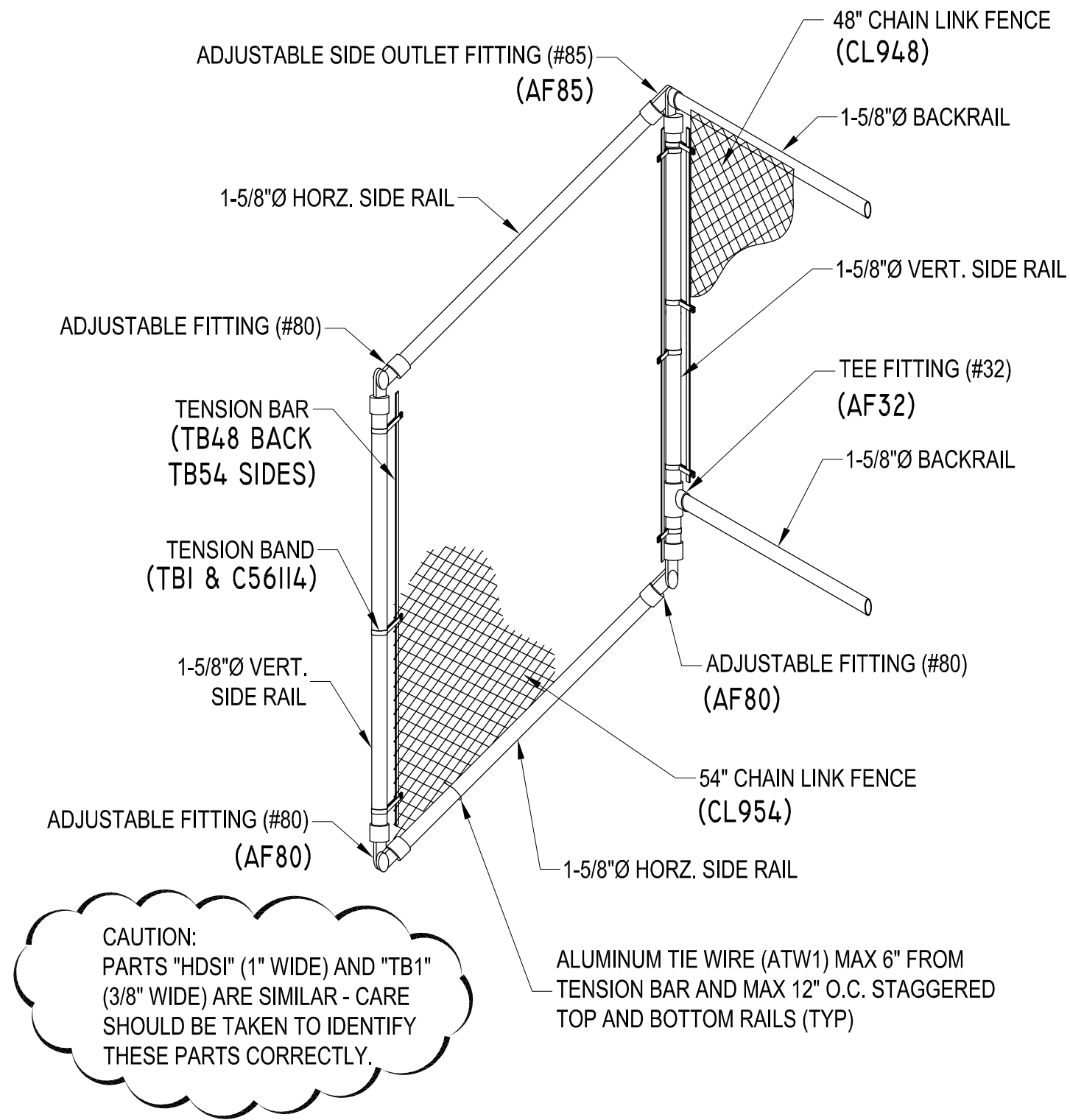

CAUTION:
PARTS "HDSI" (1" WIDE) AND "TB1"
(3/8" WIDE) ARE SIMILAR - CARE
SHOULD BE TAKEN TO IDENTIFY
THESE PARTS CORRECTLY.

ISOMETRIC VIEW
CONNECTION DETAIL OF BACK RAIL TO SIDE RAIL

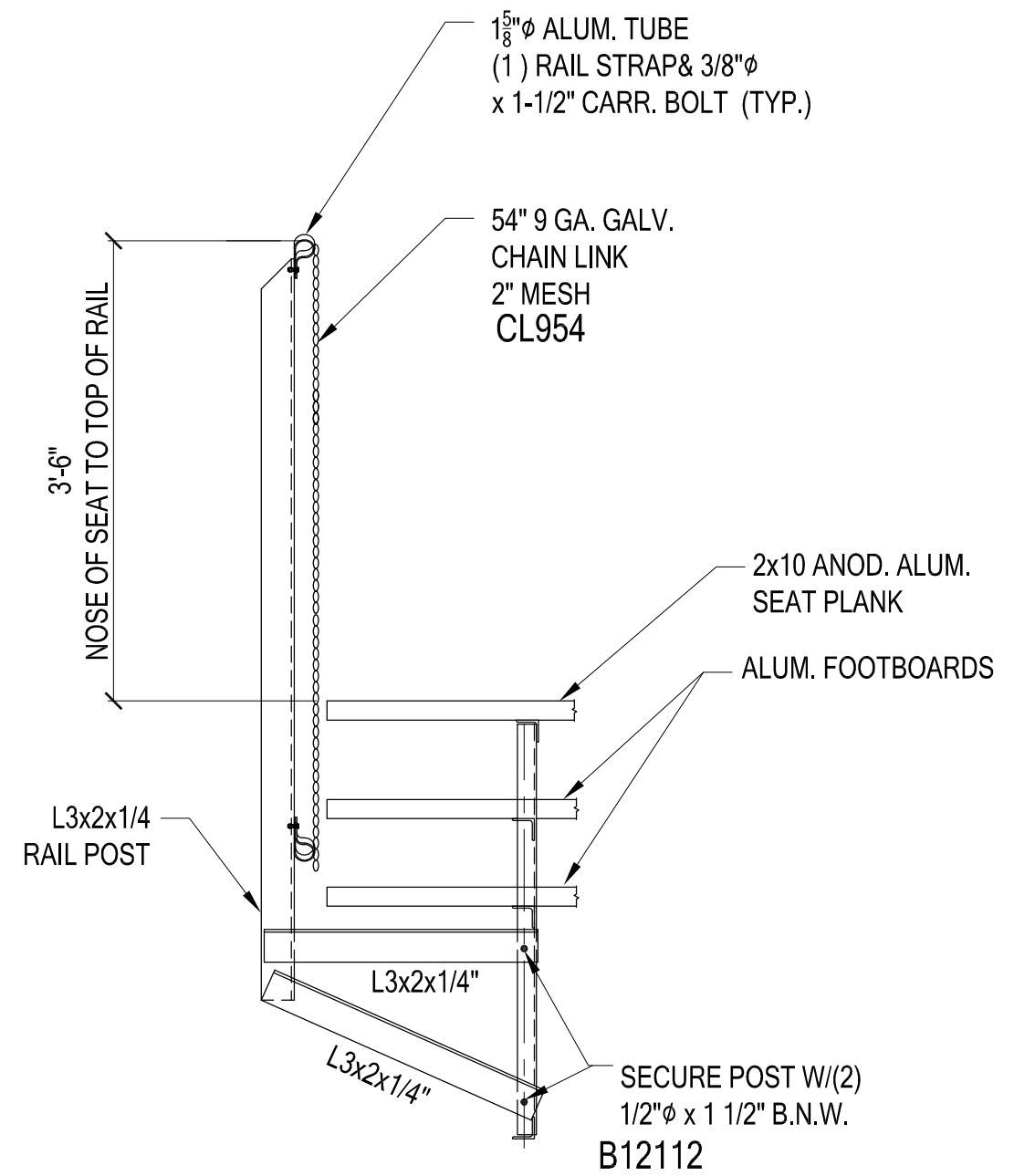

RAIL POST CONNECTION DETAIL

2810 Sydney Road
Plant City, Florida 33566
Phone: 813-305-1415
Fax: 813-305-1419
www.gtgrandstands.com

CHAINLINK DETAILS
ELEVATED ROW BLEACHER
WITH AISLE

EL-10xxADC-A AND EL-10xxGDC-A
OPTIONAL -MS (MUD SILLS)

DRAWN BY
CHECKED BY
DATE
MAY 2010
SCALE
NOTED
JOB NO.
EL-10xxADC-A
EL-10xxGDC-A
DWG NO.